

# DIGGING A TRENCH WITH A 2% SLOPE USING A ROTARY LASER

Method 1: knowing the height of the laser relative to a point.

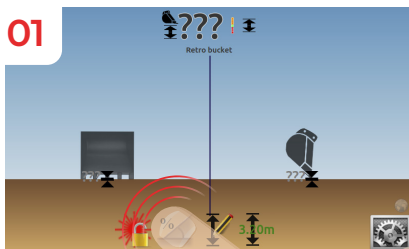

01 Activate Slope mode.

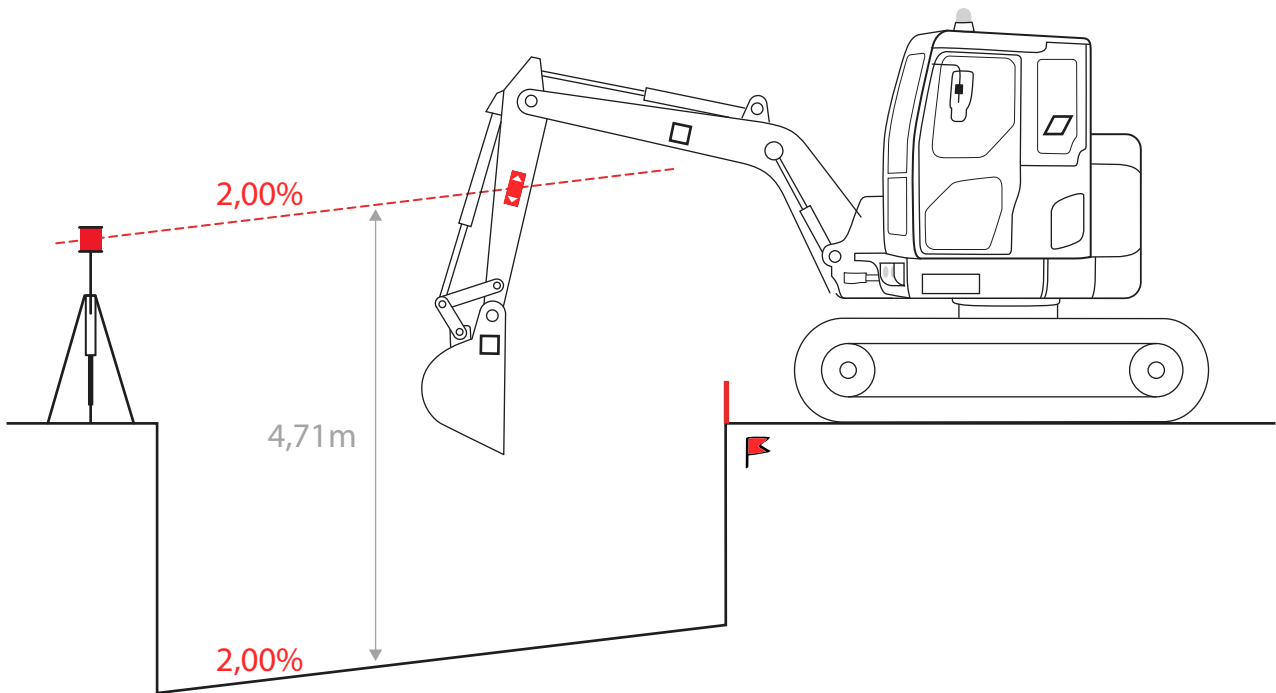
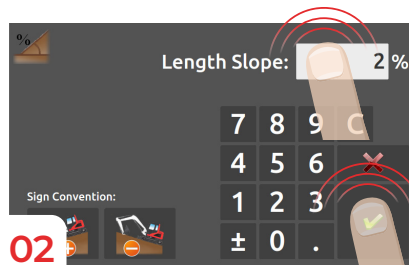

02 Enter 2%, then confirm.

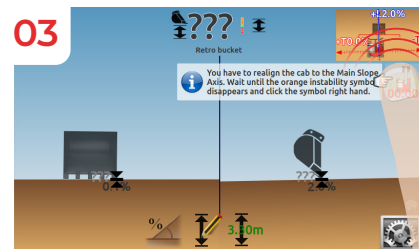

03 Align your boom with the trench.

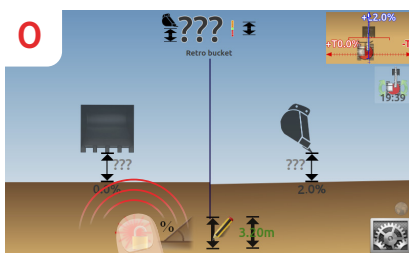

04 Activate Laser mode.

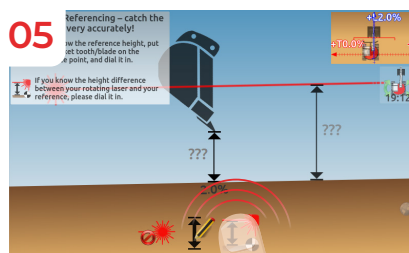

05 Click on « Define laser height ».

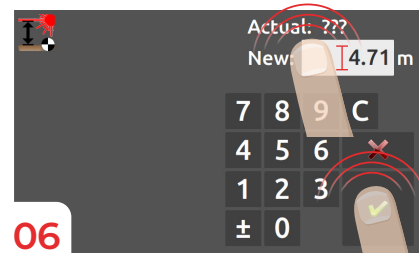

06 Enter "4.71m" and confirm.

# DIGGING A TRENCH WITH A 2% SLOPE USING A ROTARY LASER

---

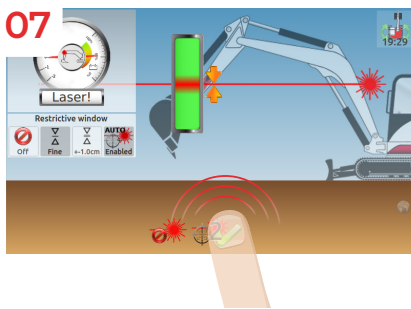

Catch the laser beam.

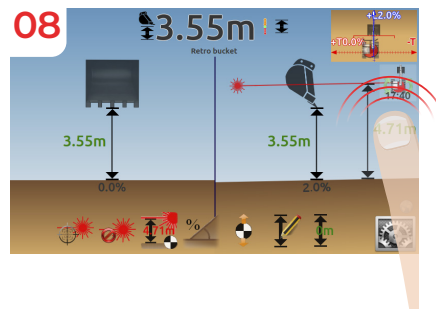

The entered laser height (4.71m) is displayed, and in this example, the calculation shows that the bucket is “**3.55m**” from the bottom of the trench.

---

# DIGGING A TRENCH WITH A 2% SLOPE USING A ROTARY LASER

Method 2: without knowing the height of the laser.

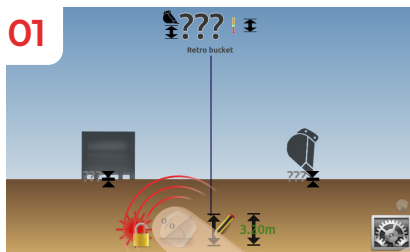
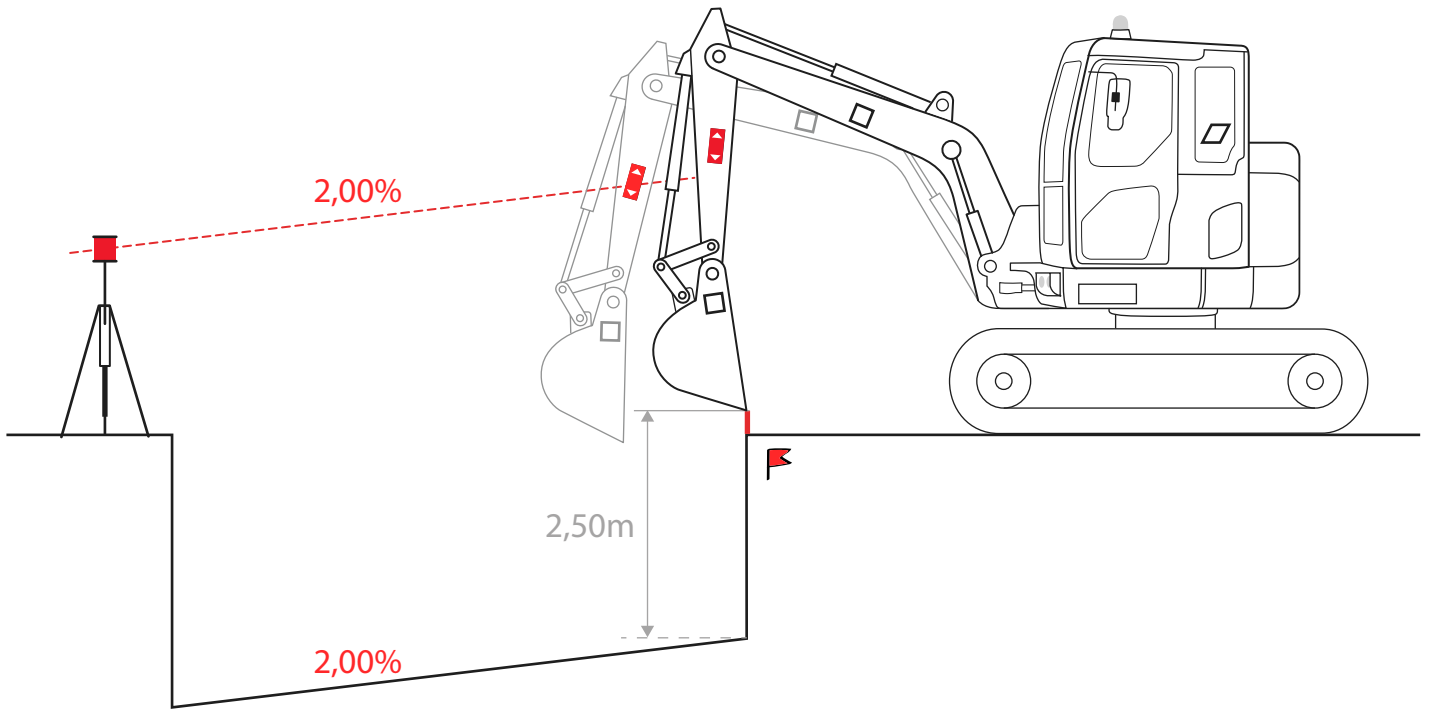

Activate Slope mode.

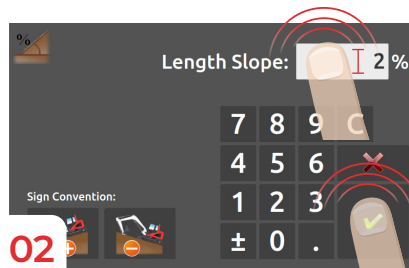

Enter 2%, then confirm.

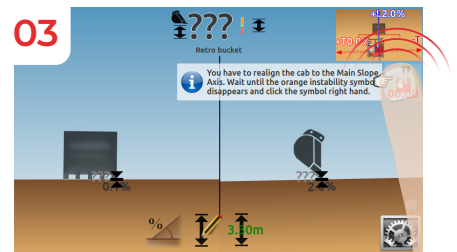

Align your boom with the trench.

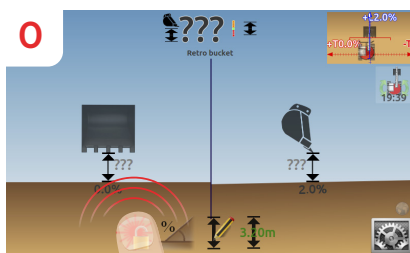

Activate laser mode.

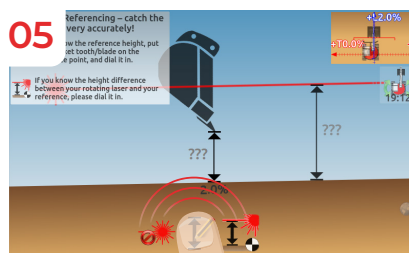

Click on « depth ».

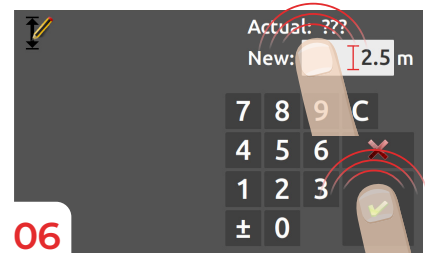

Place the bucket tip on the benchmark, then enter "2.5m" and confirm.

# DIGGING A TRENCH WITH A 2% SLOPE USING A ROTARY LASER

---

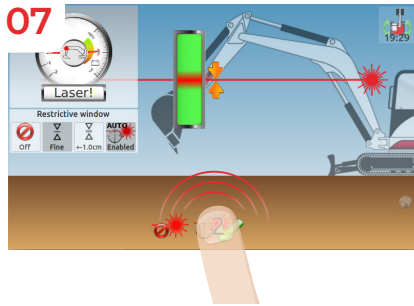

Catch the laser.

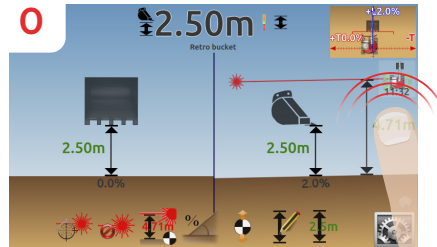

In this example, the calculation shows that the laser is "4.71m" from the bottom of the trench, and the bucket is "2.50m" from the bottom.

---